

SLIM/SPEED

GIORNO

THE DAY COLLECTION

PENSILI, BASI
E SISTEMA A SPALLA

wall units, bases
and modular system

DA
DALL'AGNESE

COLLEZIONE **GIORNO**

day collection

DA
DALL'AGNESE

SLIM / SPEED

DAY COLLECTION



Una zona giorno da rendere propria con il sistema modulare dei contenitori componibili Slim oppure con quello a spalla portante Speed. Perfettamente integrabili fra loro, creano spazi moderni, razionali e attrezzati per ogni esigenza con un carattere spiccato, sempre personale.

A living room area to make your own using the modular system of Slim mix and match storage units, or Speed units with structural side panels. They integrate perfectly with each other to create modern rational areas equipped for all needs, personal and full of character.

Der Wohnbereich kann mit dem modular aufgebauten System der anbaufähigen Stauraumelemente Slim oder mit dem System mit tragenden Seitenteilen Speed individuell gestaltet werden. Sie integrieren sich perfekt ineinander, schaffen moderne und rationelle Räume mit ausgeprägtem und stets individuellem Eigencharakter, deren Einrichtung den jeweiligen Bedürfnissen angepasst werden kann.

Une zone jour à adapter selon ses goûts avec le système modulaire des rangements modulables Slim ou bien avec celui à élément portant Speed. Parfaitement intégrable les uns avec les autres, ils créent des espaces modernes, rationnels et équipés pour chaque exigence avec un caractère prononcé, toujours personnel.

Una zona de día para hacer propia con el sistema componible de los contenedores modulares Slim o con el sistema con panel lateral portante Speed. Perfectamente integrables entre sí, crean espacios modernos, funcionales y equipados para cualquier exigencia con un marcado carácter, siempre personal.

Дневная зона станет неповторимой благодаря модульной коллекции шкафов Slim или коллекции опорных боковин Speed. Они отлично сочетаются, между собой создают современные, практичные и удобные интерьеры, которые удовлетворяют любые требования, при этом им присущ яркий и индивидуальный стиль.

/ GIORNO

DAY

SLIM

COMP 100
COMP 101
COMP 102
COMP 103
COMP 104
COMP 87
COMP 88
COMP 105
COMP 89
COMP 106
COMP 107
COMP 62
COMP 108
COMP 109
COMP 110
COMP 111

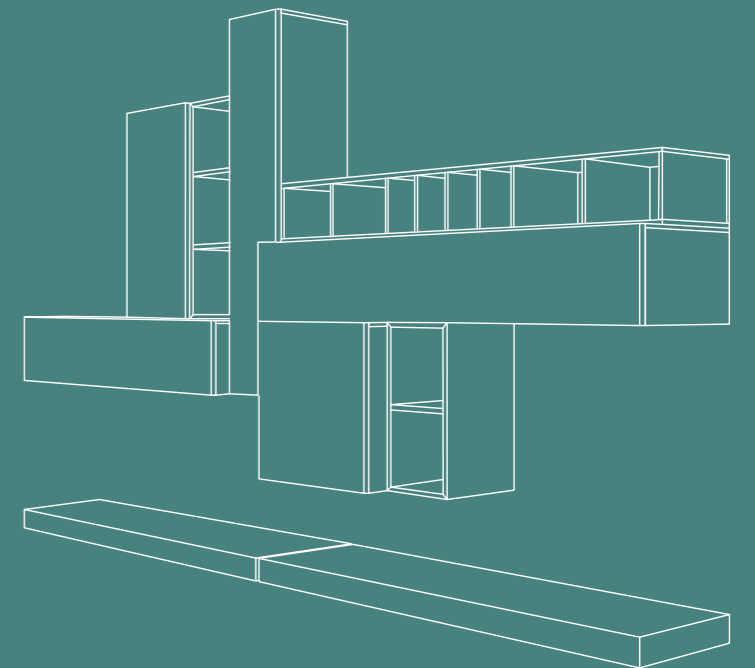

UN SISTEMA, INFINITE COMBINAZIONI

a modular system with infinite combinations

SLIM

Slim è versatilità destrutturata:
basi in appoggio o sospese, vani
a giorno ed elementi chiusi in elegante
rovere nodi naturale o termotrattato,
nelle resine più attuali
o negli intramontabili laccati,
lucidi od opachi. Fra gli elementi,
anche mensole, porta TV
e panche a terra, funzionali
e dal gusto contemporaneo.

Slim is destructured versatility: free-standing or
suspended bases, open units and closed elements in
elegant oak with natural knots or heat treated, ultra
trendy resins or timeless glossy or matt lacquers.
The items include functional shelves, TV stands and
floor benches with a contemporary air.

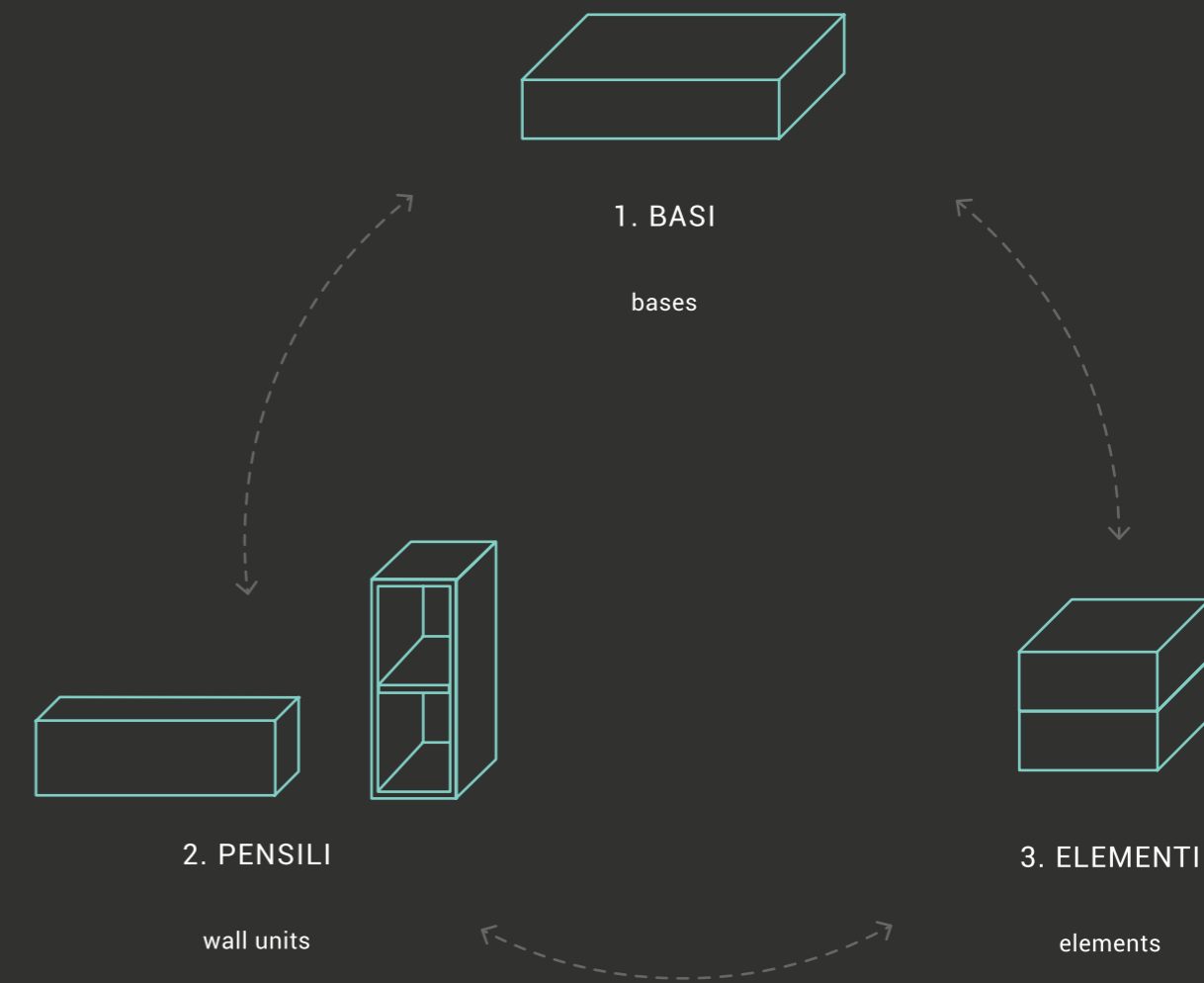



/ SLIM

DAY COLLECTION

COMP 100

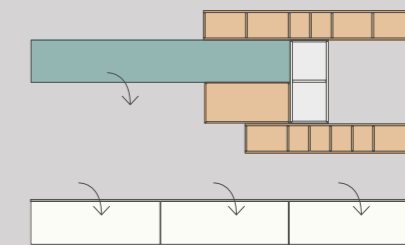

—> dimensioni/dimensions: L 2880 H 1950 P/D 484 mm

Composizione a sviluppo orizzontale con un'alternanza fra elementi a giorno e chiusi.

Anbaulösung mit horizontalem Verlauf und abwechselnd angeordneten offenen und geschlossenen Elementen.

Composición de desarrollo horizontal con una alternación entre elementos abiertos y cerrados.

Horizontal composition alternating open and closed units.

Composition à développement horizontal avec une alternance entre les éléments ouverts et fermés.

Горизонтальная композиция и чередование элементов со створками и без них.



→ FINITURE / FINISHES



basi in laccato opaco bianco 9003
bases in white 9003 matt lacquer
elementi a giorno in rovere nodi e laccato
opaco bianco 9003 / *open units in oak*
knots and white 9003 matt lacquer
pensili in laccato opaco grigio garda 246
wall unit in garda grey 246 matt lacquer





/ SLIM

DAY COLLECTION

COMP 101

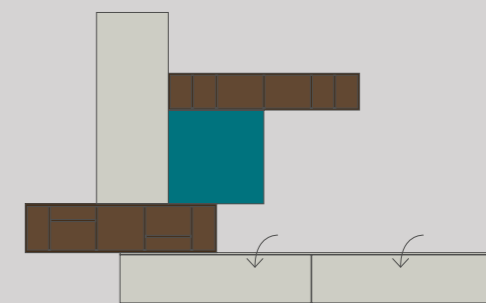

→ dimensioni/dimensions: L 3200 H 2150 P/D 484 mm

I contenitori componibili Slim permettono infiniti giochi di volumi e profondità.

Die anbaufähigen Stauraumelemente Slim lassen bei Volumen und in der Tiefe unendliche spielerische Gestaltungen zu.

Los contenedores modulares Slim permiten infinitos juegos de volúmenes y profundidades.

Slim mix and match cabinets can be used for endless combinations of volumes and depths.

Les rangements modulables Slim permettent d'infinis jeux de volumes et de profondeurs.

Модульные шкафы Slim создадут бесконечную игру объемов и глубин.

Il brio del verde petrolio è reso caldo dall'abbinamento con il rovere termotrattato.

Das lebhaftes Petroleumgrün wirkt durch die Kombination mit wärmebehandelter Eiche warm.

El brio del verde petróleo se vuelve cálido por la combinación con el roble termotrattado.

Heat treated oak softens the verve of petrol green.

Le brio du vert pétrole est réchauffé par l'assemblage avec le chêne-rouvre thermotraité.

Яркость цвета verde petrolio становится теплой и уютной за счет сочетания с термообработанным дубом.





→ FINITURE / FINISHES



basi in laccato opaco light grey
bases in light grey matt lacquer
elementi a giorno in rovere termotrattato
open units in heat-treated oak
pensili in verde petrolio 5021 e laccato opaco light grey
wall unit in petrol green 5021 and light grey matt lacquer





/ SLIM

DAY COLLECTION

COMP 102

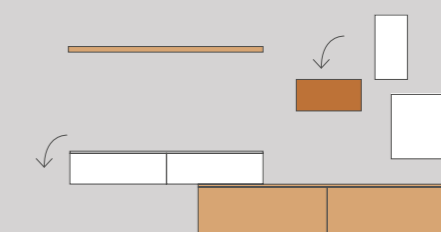

→ dimensioni/dimensions: L 3840 H 2200 P/D 484 mm

I contenitori Slim sono piacevoli per colori e materiali, razionali per la pulizia formale.

Die Stauraumelemente Slim bestechen durch ihre angenehmen Farben und Materialien sowie ihre rationellen und puristischen Formen.

Los contenedores Slim son agradables por colores y materiales, funcionales por la elegancia formal.

Slim cabinets are rational with their uncluttered formal lines in attractive materials and colours.

Les rangements Slim sont agréables pour leurs couleurs et leurs matériaux, rationnels pour la sobriété de leur forme.

Модули Slim привлекают цветами и выбором материалов, практичностью и чистотой линий.





→ FINITURE / FINISHES



basi in rovere nodi e laccato opaco bianco 9003
bases in oak knots and white 9003 matt lacquer
pensili in laccato opaco bianco e bruciato 173
wall unit in white 9003 and "burned" colour 173 matt lacquer
mensola in rovere nodi / *shelf in oak knots*

→ FINITURA TAVOLINI ZOE
 ZOE COFFEE TABLES FINISHES



piano e struttura in laccato opaco verde finlandia 199 / *top and structure in finland green 199 matt lacquer*
piano in laccato opaco bruciato 173
top in "burned" colour 173 matt lacquer
struttura in laccato opaco grigio seta 7044
structure in silk grey 7044 matt lacquer





/ SLIM

DAY COLLECTION

COMP 103

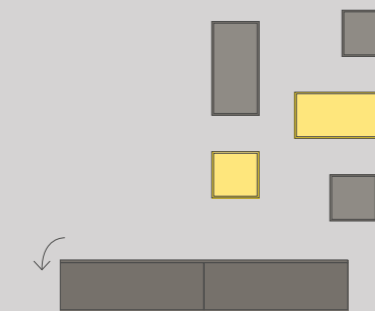

→ dimensioni/dimensions: L 2240 H 2215 P/D 484 mm

Mobili della zona giorno in libertà:
combinazione destrutturata
e un deciso tocco di colore.

Living room furniture freely arranged:
destructured combinations and
a lively touch of colour.

Beliebig angeordnete Möbel im
Wohnbereich: destrukturierte
Kombination und deutlicher
Farbakzent.

Des meubles de la zone jour en liberté:
une combinaison déstructurée
et une touche franche de couleur.

Muebles de la zona de día
en libertad: combinación
desestructurada y un toque
de color fuerte.

Свобода комбинирования шкафов
дневной зоны: необычная
композиция и решительный
яркий цвет.



28



29

→ FINITURE / FINISHES



basi in laccato opaco dark grey
bases in dark grey matt lacquer
elementi a giorno in laccato opaco
 dark grey e giallo zinco 135
*open units in dark grey and zinc
 yellow 135 matt lacquer*



/ SLIM

DAY COLLECTION

COMP 104

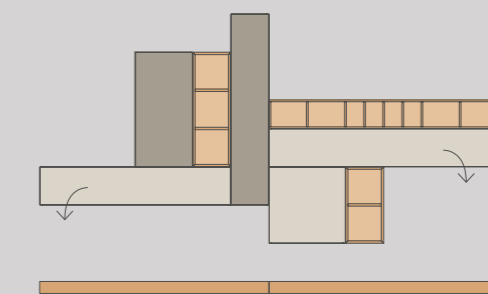

—> dimensioni/dimensions: L 3840 H 2340 P/D 484 mm

La ricca e articolata composizione sospesa è enfatizzata dalla panca a terra in rovere nodi.

This richly faceted suspended composition is highlighted by the floor bench in knotted oak.

Die umfangreiche und gegliederte, an der Wand montierte Anbaulösung wird durch das stehende Bankelement aus Eiche Astknoten betont.

La composition suspendue riche et articulée est mise en valeur par le banc au sol en chêne-rouvre nœuds.

La rica y articulada composición colgante es enfatizada por el banco de suelo en roble con nudos.

Богатая и сложная навесная композиция в контрасте с напольным элементом в сучковом дубе.



→ **FINITURE / FINISHES**



elementi a giorno in rovere nodi
open units in oak knots
pensili in laccato opaco tortora e corda
wall units in dove grey and rope colour matt lacquer
panca in rovere nodi / *bench in oak knots*

→ **FINITURA TAVOLINO ZOE**
ZOE COFFEE TABLE FINISH



piano e struttura in laccato opaco verde pallido 190 / *top and structure in pale green 190 matt lacquer*





36

/ SLIM

DAY COLLECTION

COMP 87

37

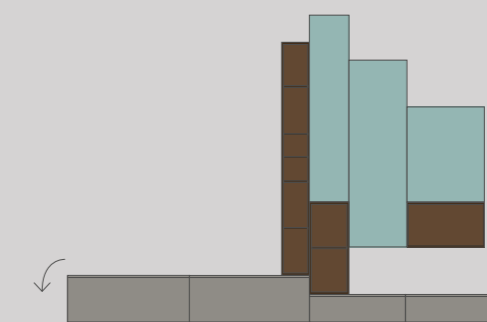

—> dimensioni/dimensions: L 3520 H 2111 P/D 484 mm

I laccati opachi sono impreziositi e scaldati dal rovere termotrattato dei vani a giorno.

Matt lacquered items are enhanced and softened by the heat treated oak of the open units.

Die Farben in Lack Matt werden durch die wärmebehandelte Eiche der offenen Fächer aufgewertet und wirken wärmer.

Les laqués mats sont enrichis et réchauffés par le chêne-rouvre thermotraité des rangements ouverts.

Los lacados opacos son valorizados y calentados por el roble termotrattado de los compartimientos abiertos.

Матовая лакировка облагорожена и обогрета термообработанным дубом открытых отделений.



→ FINITURE / FINISHES



basi in laccato opaco grigio aston 7039
bases in aston grey 7039 matt lacquer
elementi a giorno in rovere termotrattato
open units in heat-treated oak
pensili in laccato opaco grigio garda 246
wall units in garda grey 246 matt lacquer





42

/ SLIM

DAY COLLECTION

COMP 88

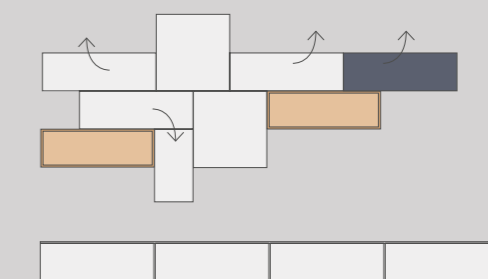

→ dimensioni/dimensions: L 3840 H 2271 P/D 484 mm

La semplicità delle basi si confronta con l'abbondanza di volumi e sovrapposizioni dei pensili.

Simple bases counteract the large volumes and overlaid wall units.

Schlichte Unterschränke stehen fülligen Volumen und übereinander angeordneten Hängeschränken gegenüber.

La simplicité des éléments bas s'oppose avec l'abondance de volumes et les superpositions des éléments hauts.

La sobriedad de los muebles bajos se compara con los volúmenes abundantes y las sobreposiciones de los muebles colgantes.

Простота напольных шкафов в контрасте с большим количеством и сочетанием навесных шкафов.

43



La ricchezza di materiali permette eleganti rimandi con la zona pranzo.

Hochwertige Materialien verleihen dem Essbereich ein elegantes Aussehen.

La riqueza de los materiales permite elegantes conexiones con la zona comedor.

Sumptuous materials create elegant references to the dining area.

La richesse des matériaux permet d'élégants rappels avec la zone repas.

Богатство материалов напоминает элегантность столовой комнаты.



→ FINITURE / FINISHES



basi in laccato opaco bianco 9003
bases in white 9003 matt lacquer
elementi a giorno in rovere nodi
open units in oak knots
pensili in laccato opaco bianco 9003 e blu
 piombo 255 / *wall units in white 9003 and*
gun metal blue 255 matt lacquer

→ FINITURA TAVOLO RADAR
RADAR TABLE FINISH



piano in rovere nodi / *top oak knots*
struttura in laccato opaco bianco 9003
structure in white 9003 matt lacquer



/ SLIM

DAY COLLECTION



COMP 105

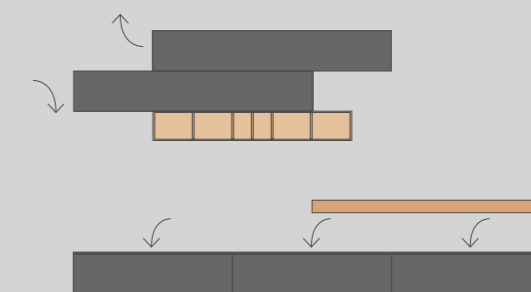

→ dimensioni/dimensions: L 3840 H 1900 P/D 484 mm

Uno stile caldo e moderno:
basi e pensili in effetto resina
dark grey e stacchi in rovere nodi.

Ein warmer und moderner Stil:
Unterschranke und Hängeschranke
mit Kunstharzeffekt in Dark Grey,
abgesetzt mit Eiche Astnoten.

Un estilo cálido y moderno: muebles
bajos y muebles colgantes en
efecto resina dark grey y contrastes
de roble con nudos.

A warm modern style: bases and
wall units with a dark grey resin
effect finish and details in knotted oak.

Un style chaud et moderne: des
éléments bas et hauts à effet résine
dark grey et contrastes en chêne-
rouvre nœuds.

Современный стиль, создающий
тепло в доме: напольные и навесные
шкафы с эффектом мягкой отделки
в цвете dark grey и сучковом дубе.



→ **FINITURE / FINISHES**



basi in effetto resina dark grey
bases in dark grey resin effect finish
elementi a giorno e piano sospeso in rovere nodi
open units and hanging bench in oak knots
pensili in effetto resina dark grey
wall units in dark grey resin effect finish

52



53

→ **FINITURA TAVOLINO ZOE**
ZOE COFFEE TABLE FINISH



piano e struttura in laccato opaco light grey / *top and structure in light grey matt lacquer*



/ SLIM

DAY COLLECTION

COMP 89

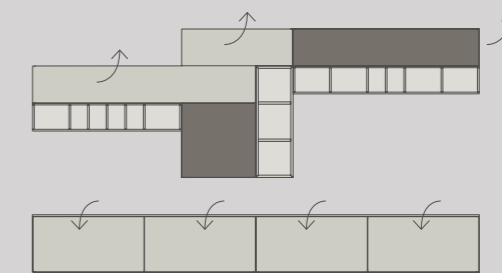

→ dimensioni/dimensions: L 3840 H 2111 P/D 484 mm

Equilibrio di pieni e vuoti per arredare con gusto un salotto raffinato e contemporaneo.

Ausgewogene volle und leere Volumen, um ein zeitgemäßes Wohnzimmer edel und geschmackvoll einzurichten.

Equilibrio de llenos y vacíos para decorar con gusto una sala de estar refinada y actual.

Well-balanced full and empty spaces tastefully furnish a refined contemporary living room.

Équilibre de pleins et de vides pour meubler avec goût un salon raffiné et contemporain.

Гармония модулей со створками и без них для стильного, современного интерьера изысканной гостиной.



Sempre pratiche le ante a ribalta dal basso verso l'alto.

Highly practical lift-up doors.

Immer praktisch sind die Klapptüren von unten nach oben.

Toujours pratiques, les portes relevables de bas en haut.

Son siempre cómodas las puertas abatibles de abajo hacia arriba.

Откидные вверх створки всегда практичны.

→ FINITURE / FINISHES



basi in laccato opaco light grey
bases in light grey matt lacquer
elementi a giorno in laccato opaco light grey
open units in light grey matt lacquer
pensili in laccato opaco light e dark grey
wall unit in light and dark grey matt lacquer





/ SLIM

DAY COLLECTION

COMP 106

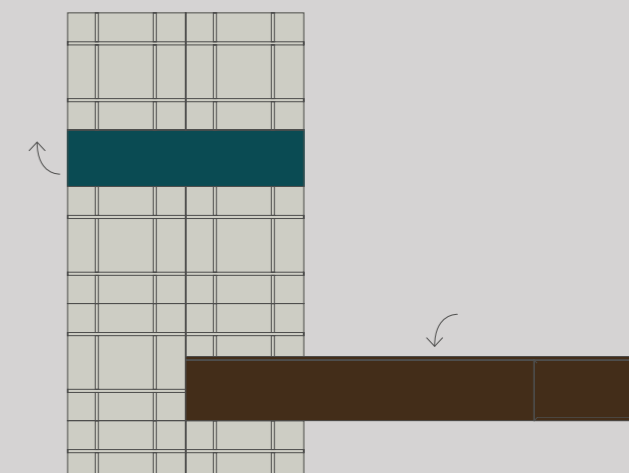

—> dimensioni/dimensions: L 3200 H 2560 P/D 484 mm

Il pensile sospeso in rovere termotrattato conferisce imponenza alla slanciata libreria.

Der Hängeschrank aus wärmebehandelter Eiche lässt das schmale Bücherregal imposant wirken.

El mueble colgante de roble termoestructurado proporciona majestuosidad a la esbelta librería.

A heat treated oak suspended wall unit gives the slender bookshelves an imposing air.

L'élément haut suspendu en chêne-rouvre thermotraité confère une majesté à la bibliothèque élancée.

Подвесной элемент в термообработанном дубе придает важность всей вытянутой композиции.



→ FINITURE / FINISHES



base in rovere termotrattato
bases in heat-treated oak
scaffalature pensili in laccato opaco light grey
wall shelving system in light grey matt lacquer
pensile in laccato opaco verde finlandia 199
wall unit in finland green 199 matt lacquer



64

Moduli aperti e chiusi
si fondono con naturalezza.

Offene und geschlossene Module
verschmelzen auf natürliche
Weise miteinander.

Módulos abiertos y cerrados
se fusionan con naturalidad.

Open and closed modules
blend with nonchalance.

Des modules ouverts et fermés
se fondent avec naturel.

Естество сочетания модулей
со створками и без них.



65

→ **FINITURA TAVOLINI ZOE**
ZOE COFFEE TABLES FINISHES



piano e struttura in laccato opaco verde finlandia 199 / *top and structure in finland green 199 matt lacquer*
piano in laccato opaco rosso bordeaux 3005 / *top in bordeaux red 3005 matt lacquer*
struttura in rovere termotrattato / *structure in heat-treated oak*



68

/ SLIM

DAY COLLECTION

COMP 107

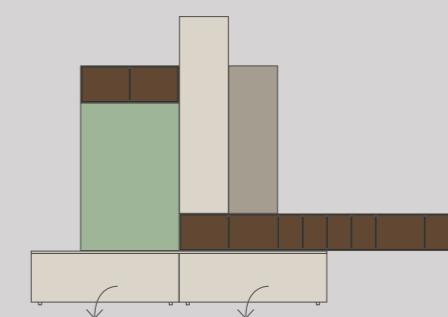

→ dimensioni/dimensions: L 2880 H 1871 P/D 484 mm

Una composizione davvero compatta, alleggerita dai vani a giorno orizzontali.

Eine wirklich kompakte Anbaulösung, die durch horizontale offene Fächer leichter wirkt.

Una composición realmente compacta, aligerada por los compartimentos abiertos horizontales.

A truly compact composition, relieved by horizontal open units.

Une composition vraiment compacte, allégée par les compartiments ouverts horizontaux.

Компактная композиция, облегченная горизонтальными открытыми отделениями.

69





→ FINITURE / FINISHES



basi in laccato opaco tortora
bases in dove grey matt lacquer
elementi a giorno in rovere termotrattato
open units in heat-treated oak
pensili in laccato opaco verde pallido 190,
 corda e tortora / *wall units in pale green 190,*
rope matt lacquer and dove grey





/ SLIM

DAY COLLECTION

COMP 62

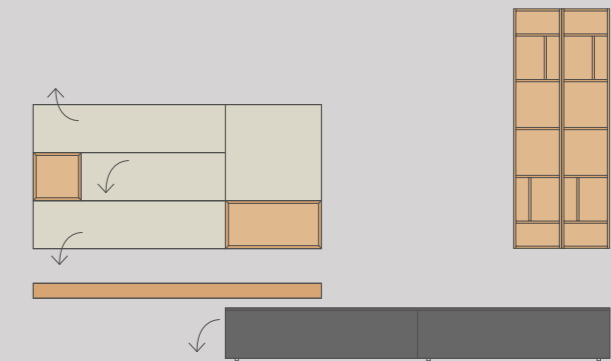

—> dimensioni/dimensions: L 3840 H 2350 P/D 484 mm

Il salotto è elegante e composito, con moduli che lo rendono attrezzato e funzionale.

Das elegant und passend eingerichtete Wohnzimmer ist mit funktionalen Modulen ausgestattet.

La sala de estar es elegante y compuesta, con módulos que la vuelven equipada y funcional.

An elegant mix of furniture for a living room equipped with functional modules.

Le salon est élégant et composé, avec des modules qui le rendent équipé et fonctionnel.

Практичные и функциональные модули для элегантной гостиной.



Anche i semplici vani a giorno offrono svariate soluzioni.

Auch schlichte offene Fächer bieten unterschiedliche Lösungen.

Incluso los simples compartimientos abiertos ofrecen distintas soluciones.

Simple open units also provide several different solutions.

Même les simples compartiments ouverts offrent des solutions variées.

Даже с простыми открытыми отделениями можно придумать множество решений.



→ FINITURE / FINISHES



basi in effetto resina dark grey
bases in dark grey resin effect finish
elementi a giorno e piano sospeso in rovere nodi
open units and hanging bench in oak knots
pensili in laccato opaco grigio perla 238
wall units in pearl grey 238 matt lacquer

78



79

→ FINITURE TAVOLO MAX
MAX TABLE FINISHES



basamento in laccato opaco nero 9017
base in black 9017 matt lacquer
piano in rovere nodi / *top in oak knots*



80

/ SLIM

DAY COLLECTION

COMP 108

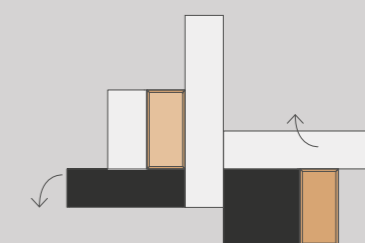

—> dimensioni/dimensions: L 2560 H 2200 P/D 384 mm

Forme geometriche a contrasto colore: ormai un classico contemporaneo di carattere.

Geometrische Formen in Kontrastfarben: inzwischen ein zeitgemäßer Klassiker mit ausgeprägtem Eigencharakter.

Formas geométricas en contraste de color: ya un clásico contemporáneo de carácter.

Geometrical shapes in contrasting colours: a contemporary classic full of character.

Des formes géométriques en contraste de couleur: désormais un classique contemporaine de caractère.

Геометрические формы в контрасте с цветом: классика яркого современного стиля.

81





→ **FINITURE / FINISHES**



elementi a giorno in rovere nodi
open units in oak knots
pensili in laccato opaco bianco 9003 e dark grey
wall units in white 9003 and dark grey matt lacquer



/ SLIM

DAY COLLECTION

COMP 109

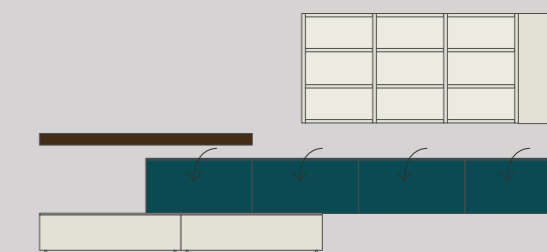

—> dimensioni/dimensions: L 4800 H 2150 P/D 580 mm

Colori raffinati per le basi sovrapposte abbinata alla spessa mensola in rovere termotrattato.

Refined colours for stacked bases matched with a thick heat treated oak shelf.

Edle Farben bei den übereinander angeordneten Unterschränken passend zum dickwandigen Bord aus wärmebehandelter Eiche.

Des couleurs raffinées pour les éléments bas superposés combinés à la tablette épaisse en chêne-rouvre thermotraité.

Colores refinados para los muebles bajos sobrepuestos combinados con la repisa espesa de roble termotratado.

Изысканные тона для модулей с полкой из термообработанного дуба.

La composizione Slim accoglie la libreria a spalla Speed.

Die Anbaulösung Slim umgibt das Bücherregal mit Seitenteil Speed.

La composición Slim acoge la librería con panel lateral Speed.

This Slim composition includes a Speed bookcase.

La composition Slim accueille la bibliothèque à élément portant Speed.

Композиция Slim со стеллажами коллекции боковин Speed.





90

91

→ FINITURE / FINISHES



base in laccato opaco ghiaccio 9002 e verde finlandia 199 / bases in ice 9002 and finland green 199 matt lacquer
libreria pensile in laccato opaco ghiaccio 9002 wall unit bookcase in ice 9002 matt lacquer
pensile in laccato opaco ghiaccio 9002 wall unit in ice 9002 matt lacquer
piano sospeso in rovere termotrattato hanging bench in heat-treated oak

/ SLIM

DAY COLLECTION



COMP 110

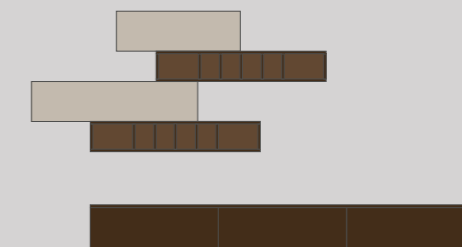

—> dimensioni/dimensions: L 3360 H 1960 P/D 484 mm

La composizione dai toni caldi e raffinati unisce il laccato lucido con l'eleganza del rovere.

This warm coloured composition combines glossy lacquer with elegant oak.

Die Anbaulösung in warmen und edlen Farbtönen verbindet Lack Hochglanz mit eleganter Eiche.

La composition des tons chauds et raffinés unit le laqué brillant à l'élégance du chêne-rouvre.

La composición de tonalidades cálidas y refinadas combina el lacado brillante con la elegancia del roble.

Композиция в теплых и утонченных тонах объединяет глянцевую лакировку с элегантностью дуба.



→ FINITURE / FINISHES



base in rovere termotrattato
bases in heat-treated oak
pensili in laccato lucido canapa
wall unit in hemp glossy lacquer
elementi a giorno in rovere termotrattato
open units in heat-treated oak





/ SLIM

DAY COLLECTION

COMP 111

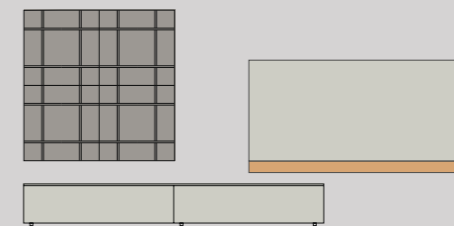

—> dimensioni/dimensions: L 3840 H 1830 P/D 484 mm

La libreria dà brio all'asciutta precisione delle basi e del porta TV con boiserie integrata.

The bookshelves bring verve to the precision of the bases and TV stand with integrated boiserie.

Das Bücherregal verleiht der trockenen Präzision der Unterschränke und des TV-Schranks mit integriertem Wandpaneel Elan.

La bibliothèque donne du brio à la précision sèche des éléments bas et du porte TV avec boiserie intégrée.

La librería da brío a la sobria precisión de los muebles bajos y del mueble para TV con boiserie integrada.

Стеллажи придают необычность строгой композиции из напольных шкафов и модуля для телевизора со встроенной настенной панелью.

La libreria è un reticolo componibile di scaffalature a giorno.

The bookshelf unit is a mix and match network of open shelves.

Das Bücherregal ist ein anbaufähiges Raster aus offenen Regalen.

La bibliothèque est un système modulable de rayonnages ouverts.

La librería es un retículo modular de estanterías abiertas.

Модульные стеллажи с открытыми отделениями.



→ FINITURE / FINISHES

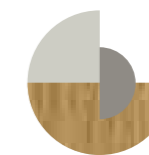

basi e boiserie in laccato opaco light grey
bases and boiserie in light grey matt lacquer
scaffalature pensili in laccato opaco dark grey
wall shelving system in light grey matt lacquer
piano sospeso in rovere nodi
hanging bench in oak knots

102



103



1. BASI / BASES

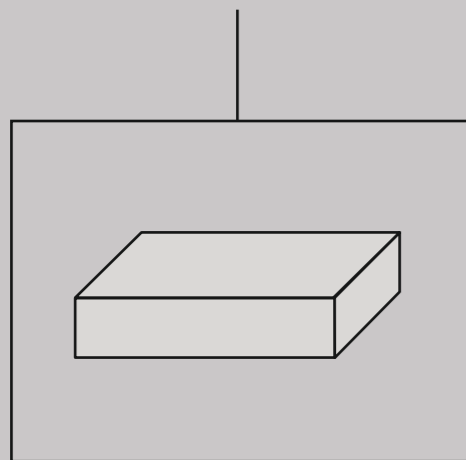

→ CON CASSETTO / WITH DRAWER

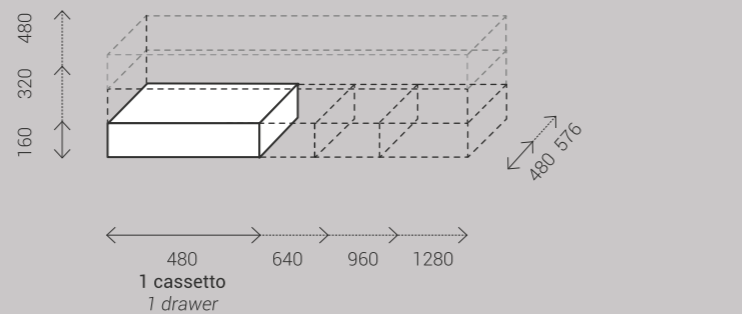

→ A RIBALTA / WITH FLAP DOOR

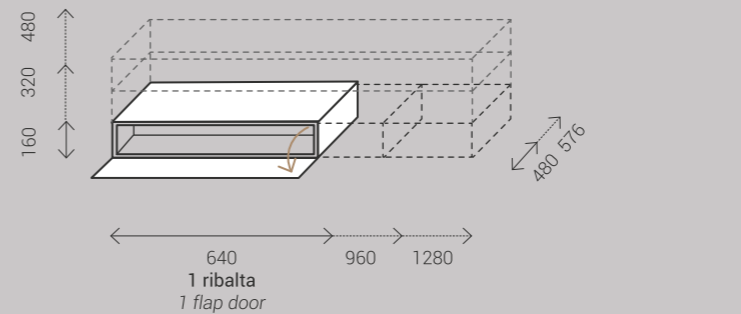

→ CASSETTO + ANTA RIBALTA / DRAWER + FLAP DOOR

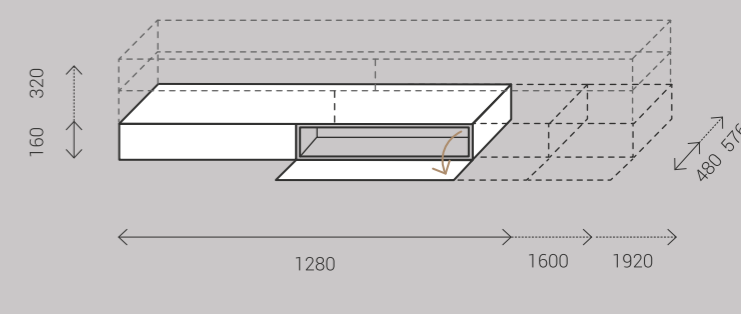

104



MONTAGGIO / ASSEMBLY

a terra, in appoggio o sospese
free-standing, supported or suspended



APERTURA / OPENING

push-pull o con maniglia
push-pull or by handle

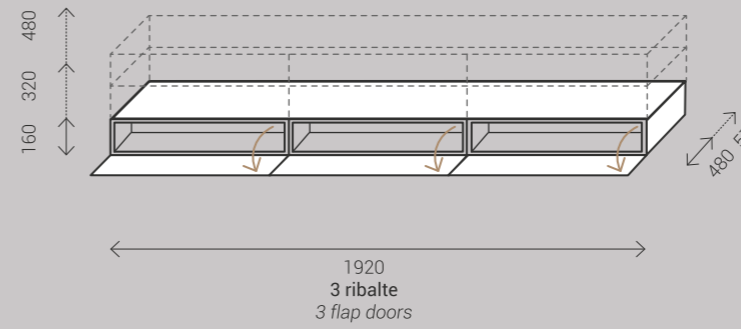
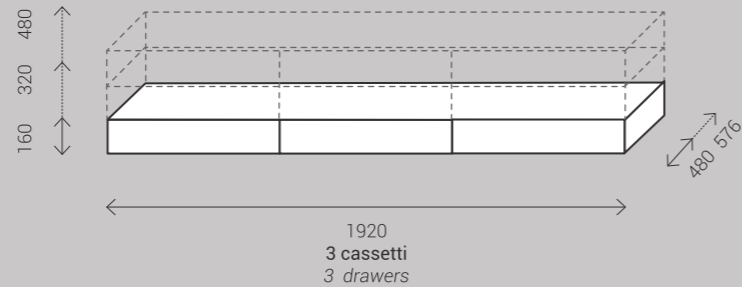
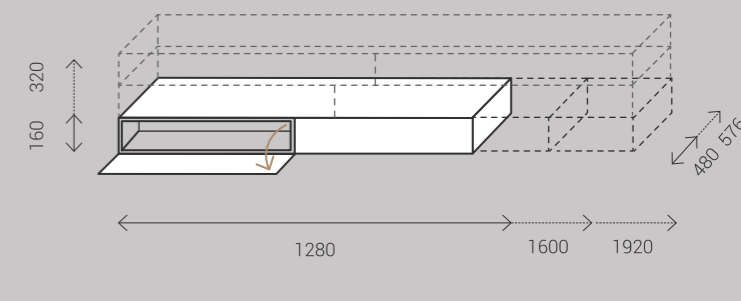
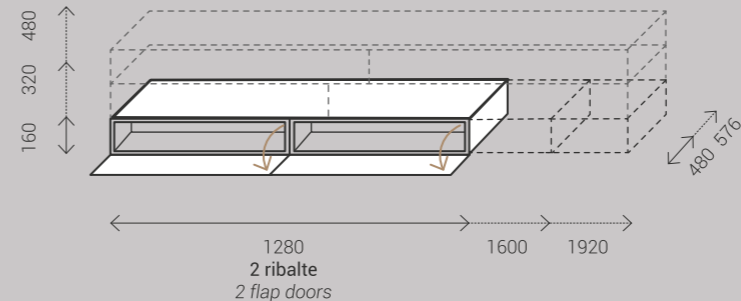
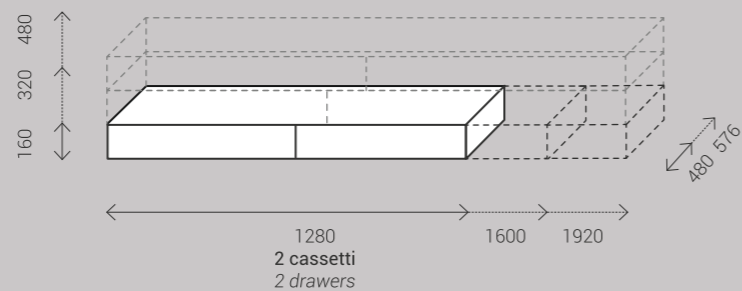

→ TOP



480 / 640 / 960 / 1280 / 1440 / 1600 / 1920 / 2240 / 2560 / 2880 / 3200 / 3520 / top intero fino a 3840 / one piece up to 3840

105

2. PENSILI / WALL UNITS

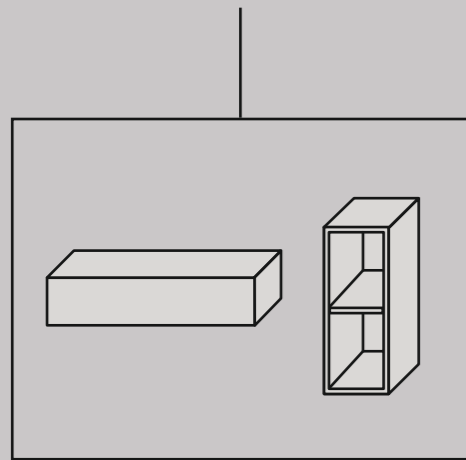

→ A RIBALTA / WITH FLAP DOOR

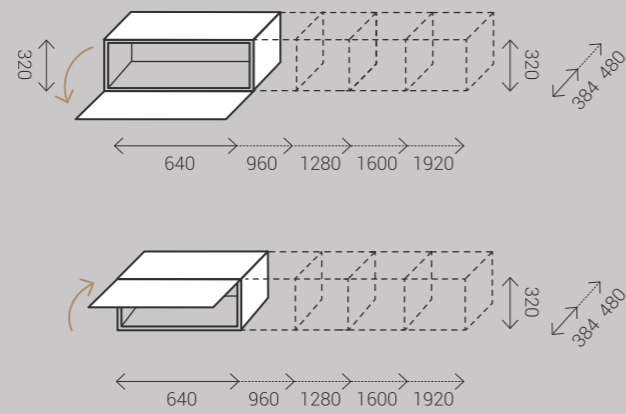

→ PENSILI A GIORNO / OPEN WALL UNITS

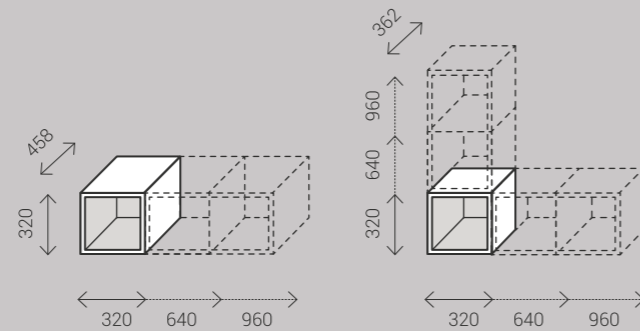

→ ANTA BATTENTE / HINGED DOOR

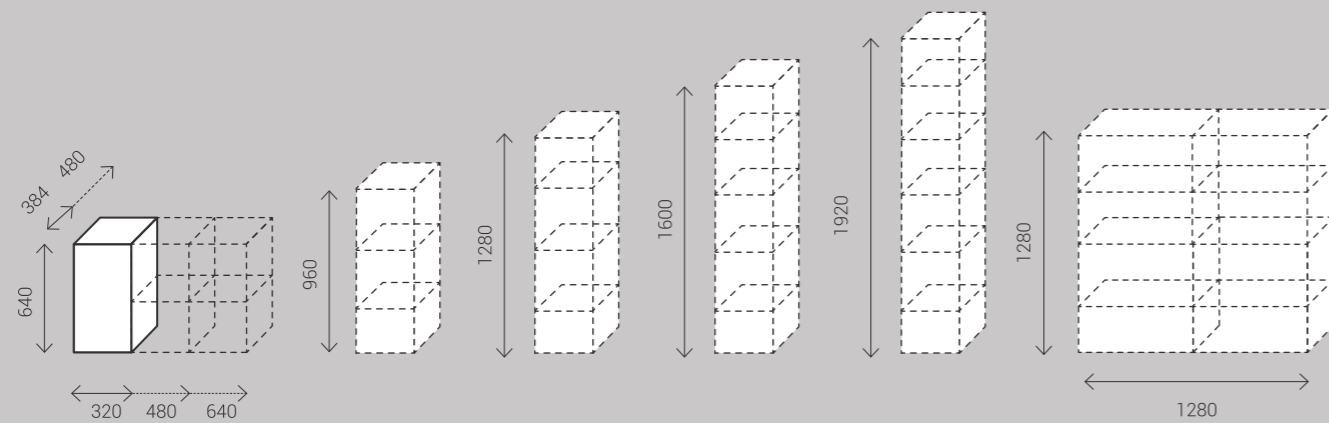

→ PENSILI A GIORNO / OPEN WALL UNITS

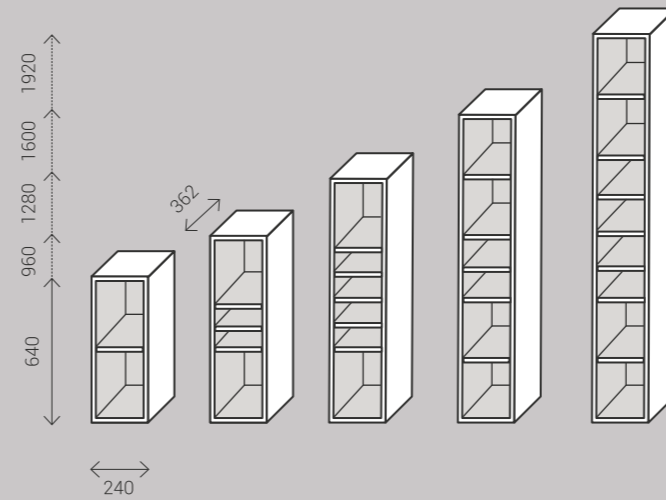

→ PENSILI IN METALLO / METAL WALL UNITS

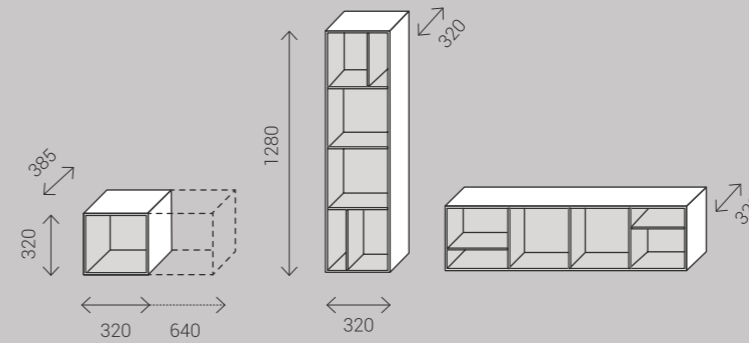

→ PENSILI A GIORNO / OPEN WALL UNITS

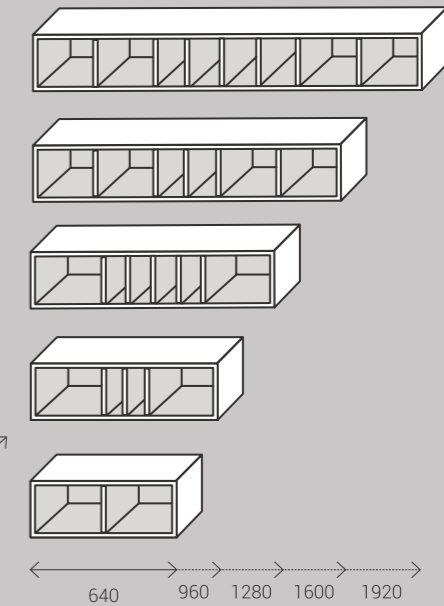
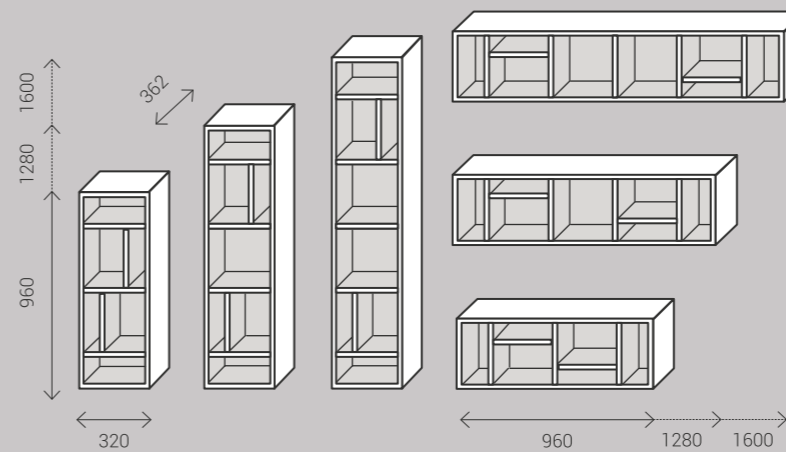

→ SCAFFALATURE / WALL SHELVING SYSTEM

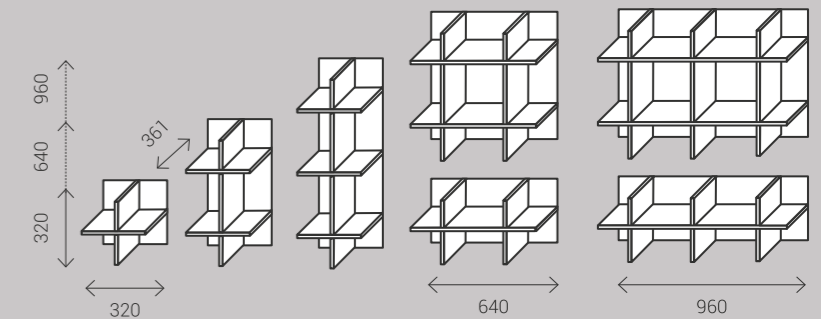

→ PIANI A TERRA O SOSPESI / FREE-STANDING OR HANGING BENCHES

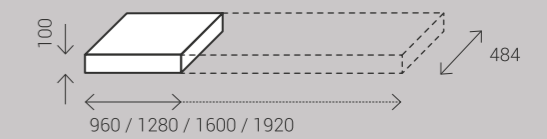

→ PANCHE / BENCHES



→ MENSOLE / SHELVES

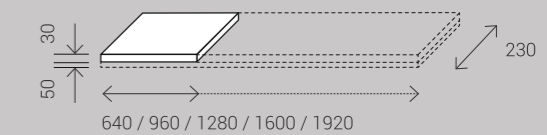

MONTAGGIO / ASSEMBLY

a terra, in appoggio o sospesi
free-standing, supported or suspended



APERTURA / OPENING

push-pull o con maniglia
push-pull or by handle

3.ELEMENTI / ELEMENTS

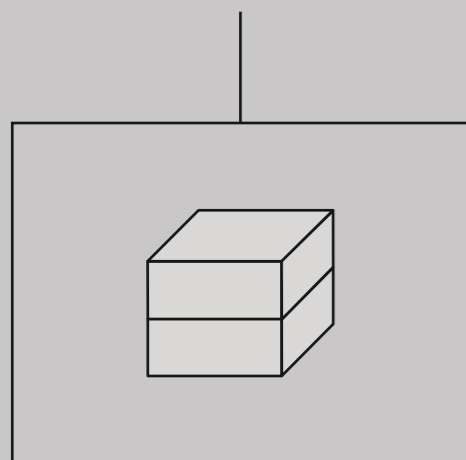

→ BATTENTI / HINGED DOORS

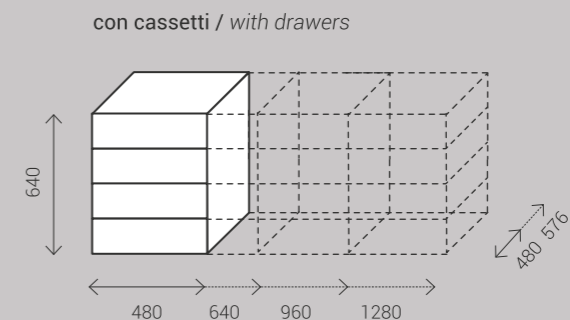
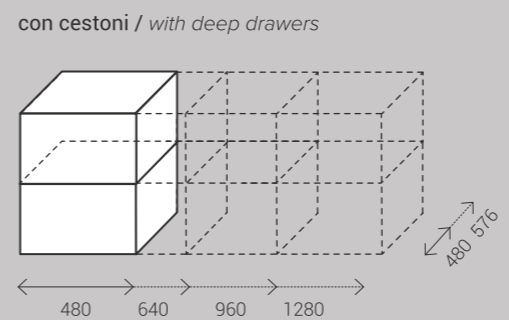
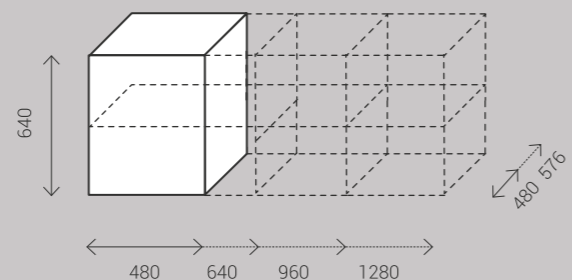
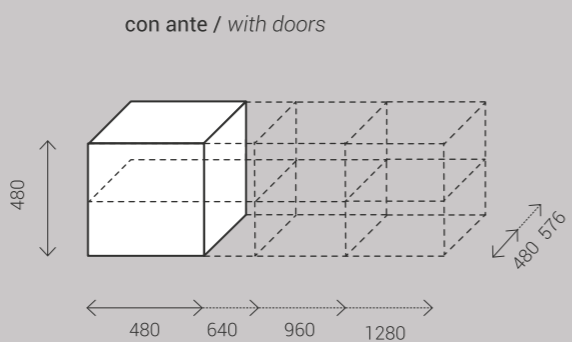

→ ESEMPI DI COMBINAZIONI / EXAMPLES OF COMBINATIONS

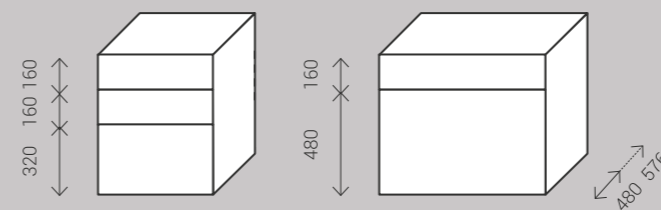

108



MONTAGGIO / ASSEMBLY

a terra, in appoggio o sospesi
free-standing, suspended



APERTURA / OPENING

push-pull o con maniglia
push-pull or by handle

→ PANNELLI BOISERIE / BOISERIE PANELS

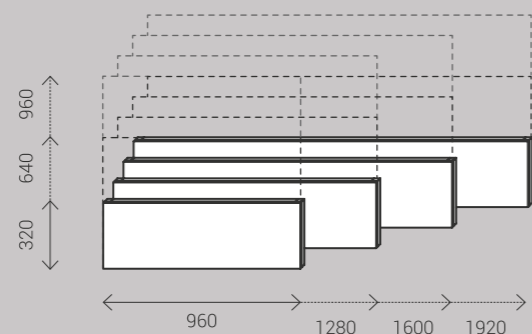

→ PORTA TV SOSPESO / SUSPENDED TV-STAND

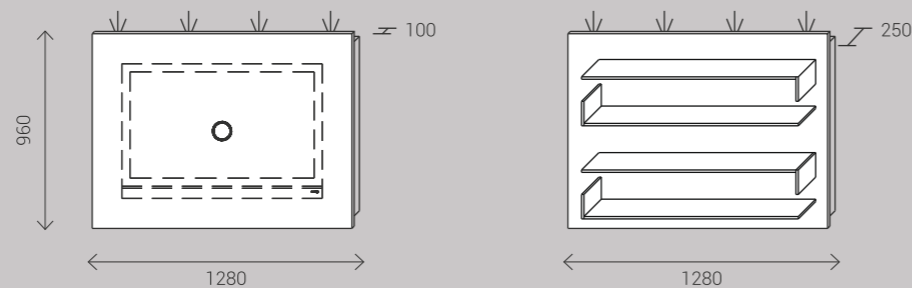

109

→ RIPIANI / SHELVES

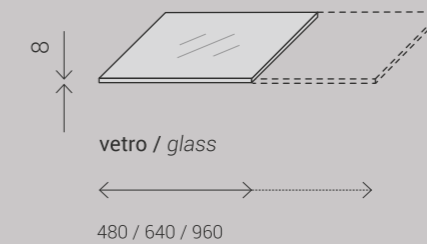
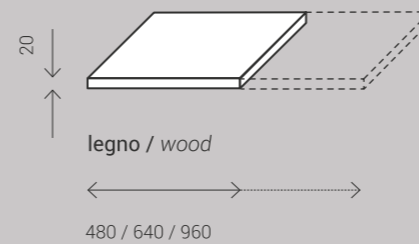

→ DIVISORI / PARTITIONS

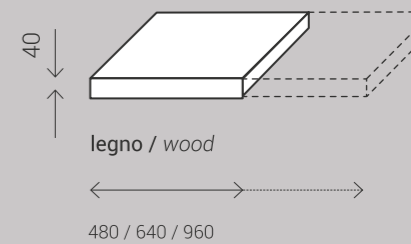

→ TOP

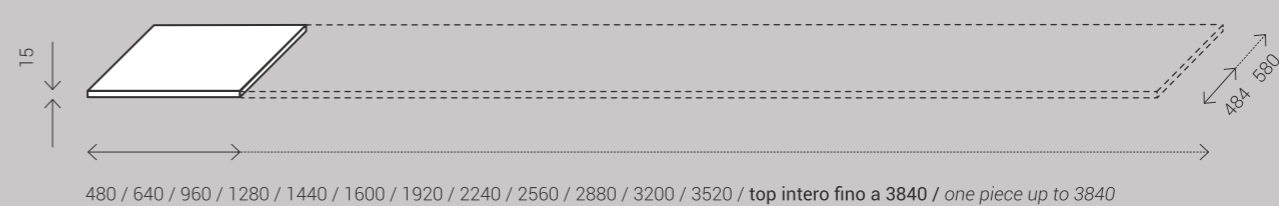

/ GIORNO

DAY

SPEED

COMP T
COMP U
COMP V
COMP Z
COMP J
COMP P
COMP K

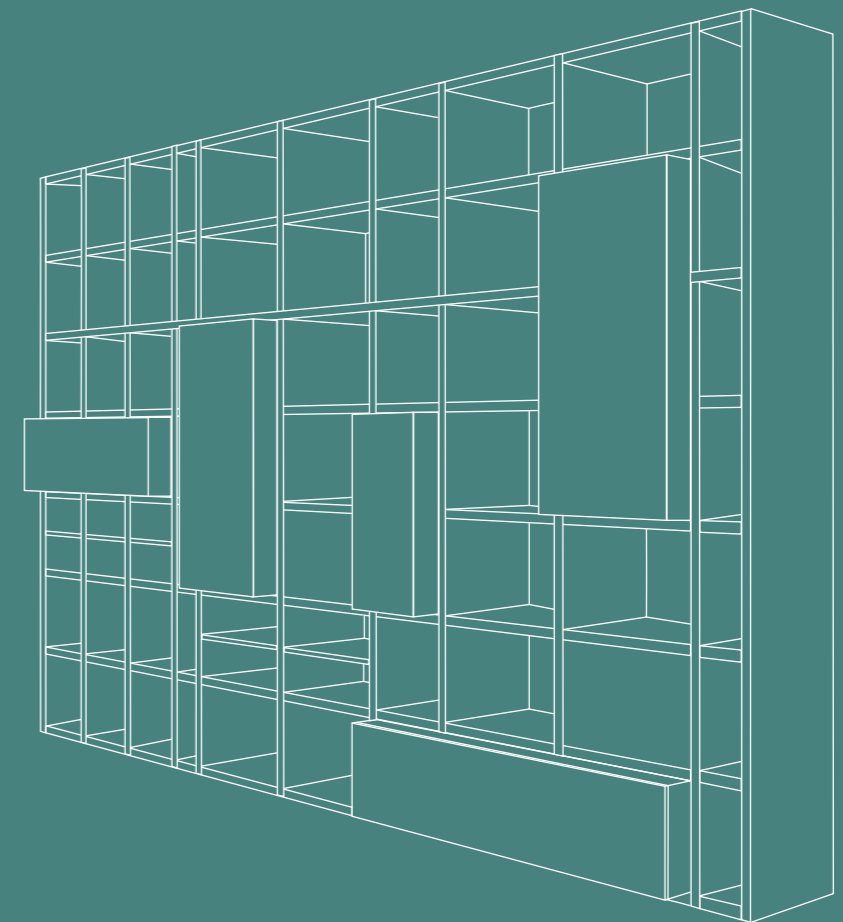

UNA SPALLA PER OGNI ESIGENZA

a structural panel for all needs

SPEED

È un sistema giorno a spalla portante
composto da fianchi, ripiani e ante,
anche scorrevoli in vetro, combinabili
in una modularità così vasta,
in larghezza e lunghezza,
da soddisfare qualsiasi esigenza.
La libreria è completata da cassetti,
cestoni attrezzati e mediacenter
nei laccati o nelle essenze più attuali.

A system of open units with structural panels, made up of side panels, shelves and doors which may also be sliding glass doors, with a vast variety of modules of different widths and lengths to make combinations that meet all needs. The bookcase is complete with lacquered or trendy wood drawers, equipped deep drawers and media centres.

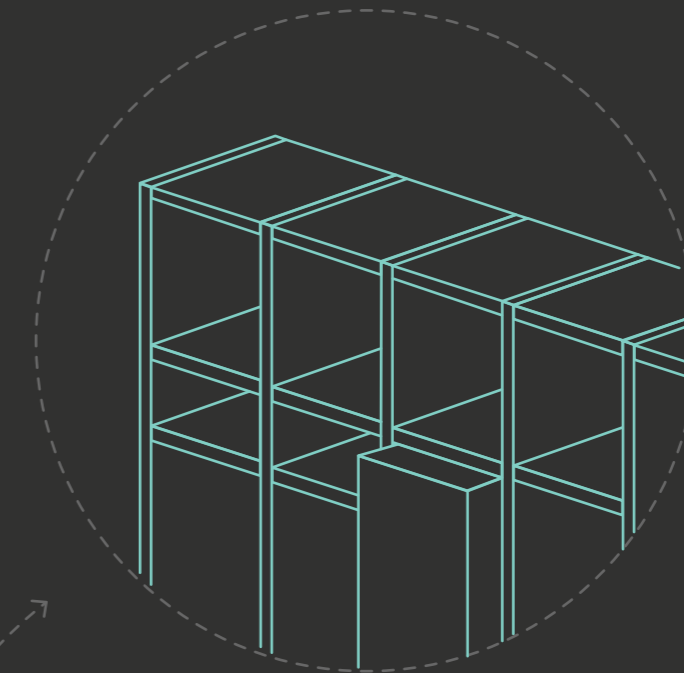

1. SPALLE, RIPIANI E SCHIENE

structural side panels, shelves and backs



2. CONTENITORI SPORGENTI ED ELEMENTI A GIORNO

open elements, jutting storage units



3. CASSETTI, CESTONI E ANTE

drawers, deep drawers and doors



/ SPEED

DAY COLLECTION

COMP T

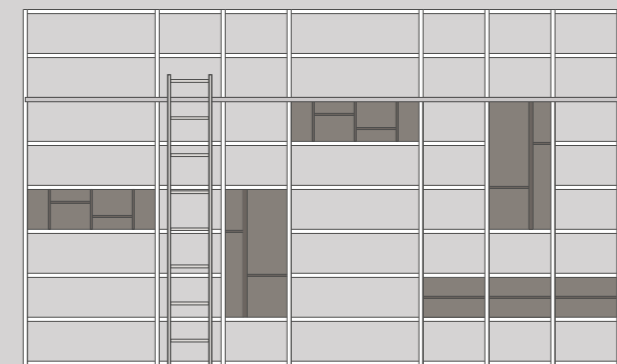

—> dimensioni/dimensions: L 4350 H 2590 P/D 362 mm

Una libreria alta, numerosi vani, tutto a portata di mano, scala compresa. È il sistema Speed.

Ein hohes Bücherregal, zahlreiche Fächer, alles griffbereit, einschließlich der Leiter. Das ist das System Speed.

Una librería alta, muchos compartimentos, todo al alcance de la mano, escalera incluida. Es el sistema Speed.

A tall bookcase, numerous compartments with everything to hand, including a ladder. This is the Speed system.

Une bibliothèque haute, de nombreux compartiments, tout à portée de main, échelle comprise. C'est le système Speed.

Высокие стеллажи, множество отделений, все очень удобно и доступно, в том числе, благодаря лестнице. Это коллекция Speed.



→ FINITURE / FINISHES



libreria in laccato opaco bianco 9003 e dark grey
bookcase in white 9003 and dark grey matt lacquer



/ SPEED

DAY COLLECTION



COMP U

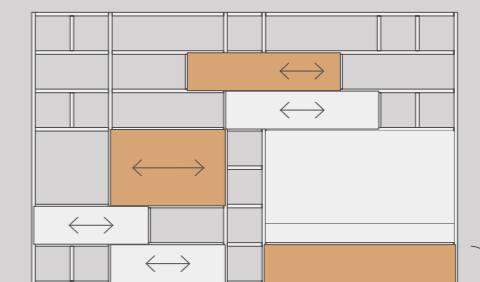

—> dimensioni/dimensions: L 3550 H 2270 P/D 362 mm

Una versione di Speed dal sapore nordico: linee pulite, bianco e rovere nodi.

Eine Version von Speed mit nordischem Charakter: klaren Linien, Weiß und Eiche Astknoten.

Una versión de Speed de estilo nórdico: líneas limpias, blanco y roble con nudos.

A Nordic style version of Speed: uncluttered lines, white and knotted oak.

Une version de Speed au style nordique: des lignes sobres, blanc et chêne-rouvre nœuds.

Вариант Speed в скандинавских традициях: чистые линии, белый цвет и сучковый дуб.



Ante a scorrimento oppure a ribalta verso il basso.

Sliding or drop down doors.

Schiebetüren oder Klapptüren nach unten.

Des portes coulissantes ou bien relevables vers le bas.

Puertas deslizantes o abatibles hacia abajo.

Раздвижные или откидные вниз створки.

→ FINITURE / FINISHES



libreria in laccato opaco bianco 9003
bookcase in white 9003 matt lacquer
ante scorrevoli e a ribalta in laccato opaco bianco 9003 e rovere nodi /sliding and flap doors in white 9003 matt lacquer and oak knots

→ FINITURA TAVOLO RADAR
RADAR TABLE FINISH



piano in rovere nodi / top oak knots
struttura in laccato opaco bianco 9003
structure in white 9003 matt lacquer



/ SPEED

DAY COLLECTION



COMP V

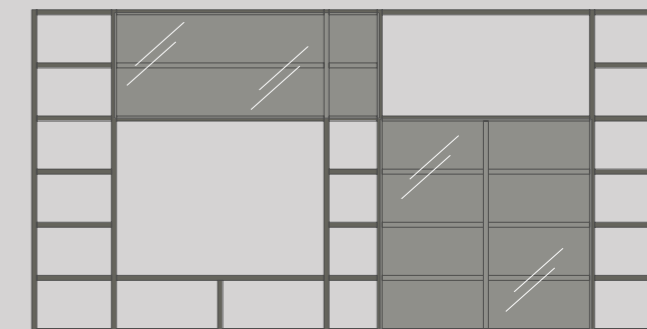

—> dimensioni/dimensions: L 3870 H 1950 P/D 362 mm

La raffinatezza della composizione risiede nei colori e nelle ampie ante scorrevoli in vetro.

Die Eleganz der Anbaulösung kommt in den Farben und den großen Schiebetüren aus Glas zum Ausdruck.

La elegancia de la composición se encuentra en los colores y en las amplias puertas correderas de cristal.

The refinement of this composition lies in its colours and large sliding glass door.

Le raffinement de la composition réside dans les couleurs et dans les grandes portes coulissantes en verre.

Цвета и большие раздвижные стеклянные створки придают композиции изысканность.





→ **FINITURE / FINISHES**



libreria in laccato opaco grigio aston 7039
bookcase in aston grey 7039 matt lacquer
ante scorrevoli in vetro sabbia scuro
sliding doors in dark sand glass

→ **FINITURE TAVOLO DIAMANTE E
 SEDIE IRIS / DIAMANTE TABLE
 AND IRIS CHAIRS FINISHES**



struttura in laccato opaco bianco
structure white matt lacquered
piano in vetro bianco / *top in white glass*

sedia Iris interamente rivestita in cuoio nero
*Iris chair structure entirely covered whit
 black hard leather*





/ SPEED

DAY COLLECTION

COMP Z

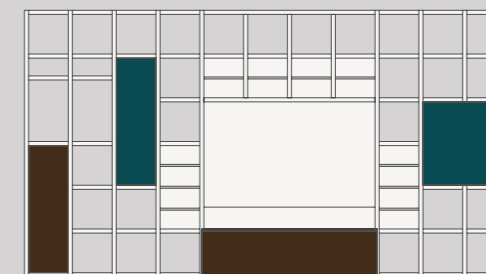

—> dimensioni/dimensions: L 3550 H 1950 P/D 362/458 mm

Sistema giorno a spalla portante Speed con un tocco di raffinatezza verde Finlandia e rovere.

Das offene System mit tragendem Seitenteil Speed und einem Hauch von Eleganz in Finnlandgrün und Eiche.

Sistema de día con panel lateral portante Speed con un toque de elegancia verde Finlandia y roble.

Speed system of open units with structural panels and the refined touch of Finland green and oak.

Système ouvert à élément portant Speed avec une touche de raffinement vert Finlande et chêne-rouvre.

Утонченность открытым отделениям и опорным боковинам Speed придают цвет verde Finlandia и дуб.



→ FINITURE / FINISHES



libreria in laccato opaco bianco 9003
bookcase in white 9003 matt lacquer
contenitori sporgenti in rovere termotrattato
 e verde finlandia 199 laccato opaco
*jutting storage units in heat-treated oak
 and finland green 199 matt lacquer*

→ FINITURA TAVOLINO ZOE
 ZOE COFFEE TABLE FINISH



piano e struttura in bruciato 173 laccato opaco
top and structure in "burned" colour 173 matt lacquer



/ SPEED

DAY COLLECTION

COMP J

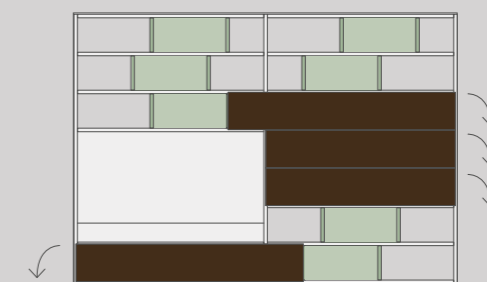

—> dimensioni/dimensions: L 3230 H 2270 P/D 362 mm

Sviluppo in orizzontale per la libreria con vani aperti e chiusi con apertura a ribalta.

Developed horizontally, this bookcase has open and closed units with drop down doors.

Horizontaler Verlauf beim Bücherregal mit offenen und geschlossenen Fächern und Klapptür.

Développement à l'horizontale avec des compartiments ouverts et fermés avec ouverture relevable.

Desarrollo horizontal para la librería con compartimentos abiertos y cerrados con apertura abatible.

Горизонтальная композиция стеллажей с отделениями с откидными створками и без них.



→ FINITURE / FINISHES



libreria in laccato opaco bianco 9003 e verde pallido 190 / *bookcase in white 9003 matt lacquer and pale green 190 matt lacquer*
ribalte in rovere termotrattato / *flap doors in heat-treated oak*

→ FINITURE TAVOLO RUBINO E SEDIE EMY / DIAMANTE TABLE AND EMY CHAIRS FINISHES



struttura in rovere termotrattato / *heat-treated oak structure*
piano in laccato opaco bianco 9003 top in white 9003 matt lacquer
sedia Emy in polipropilene bianco / *Emy chair in white polypropylene*





/ SPEED

DAY COLLECTION

COMP P

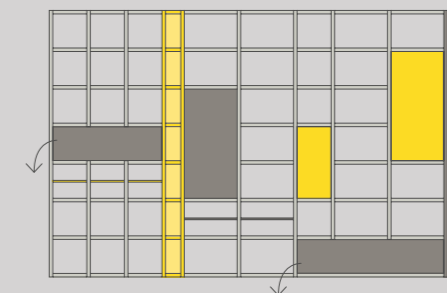

—> dimensioni/dimensions: L 3550 H 2270 P/D 362/458 mm

Un tocco di colore deciso e la composizione classica diviene fresca e giovane.

Ein Hauch von kräftiger Farbe und die klassische Anbaulösung wirkt frisch und jung.

Un toque de color fuerte y la composición clásica se vuelve fresca y joven.

A touch of bright colour makes a classical composition young and fresh.

Une touche de couleur franche et la composition classique devient fraîche et jeune.

Яркий цвет делает классическую композицию свежей и необычной.





→ FINITURE / FINISHES



libreria in laccato opaco light grey,
dark grey e giallo zinco 135
*bookcase in light grey, dark grey and zinc
yellow 135 matt lacquer*
contenitori sporgenti in laccato opaco
dark grey e giallo zinco 135
*jutting storage units in dark grey
and zinc yellow 135 matt lacquer*



/ SPEED

DAY COLLECTION

COMP K

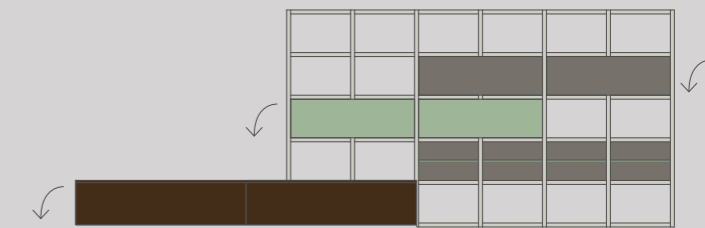

—> dimensioni/dimensions: L 4495 H 1950 P/D 484 mm

I contenitori sporgenti, con apertura a ribalta, creano un movimento di volumi d'impatto.

Protruding storage units with drop down doors create an impact.

Die vorgezogenen Stauraumelemente mit Klapptür schaffen eindrucksvolle bewegte Volumen.

Les compartiments saillants avec une ouverture relevable créent un mouvement de volumes d'impact.

Los contenedores salientes, con apertura abatible, crean un movimiento de volúmenes de impacto.

Выступающие модули и откидные створки создают субъективную игру объемов.



152

153

→ FINITURE / FINISHES



libreria in laccato opaco light grey
bookcase in light grey matt lacquer
basi e contenitori sporgenti in laccato opaco
dark grey, verde pallido190 e rovere termotrattato
*bases and jutting storage units in dark grey,
pale green 190 matt lacquer and heat-treated oak*

Il rovere consente rimandi di stile con la zona giorno.

Eiche verleiht dem Wohnraum stilvolle Anklänge.

El roble permite conexiones de estilo con la zona de día.

The use of oak echoes the style of the living room.

Le chêne-rouvre permet des rappels de style avec la zone jour.

Боковина для любых нужд.



SPEED

→ MODULARITÀ ORIZZONTALE / HORIZONTAL MODULES

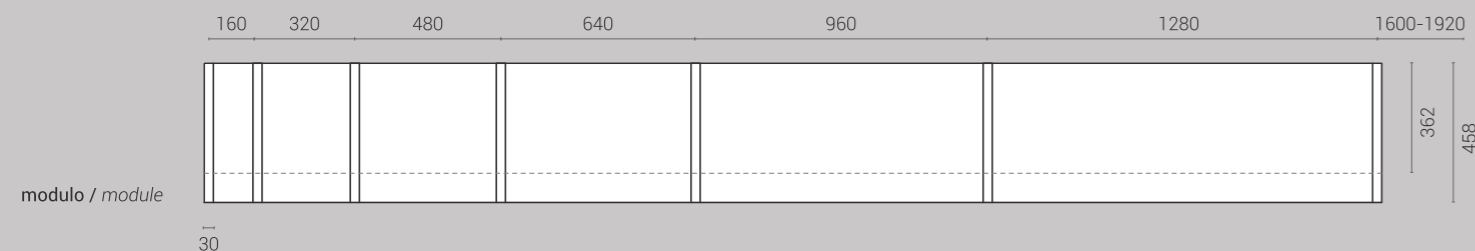

→ MODULARITÀ VERTICALE / VERTICAL MODULES

156

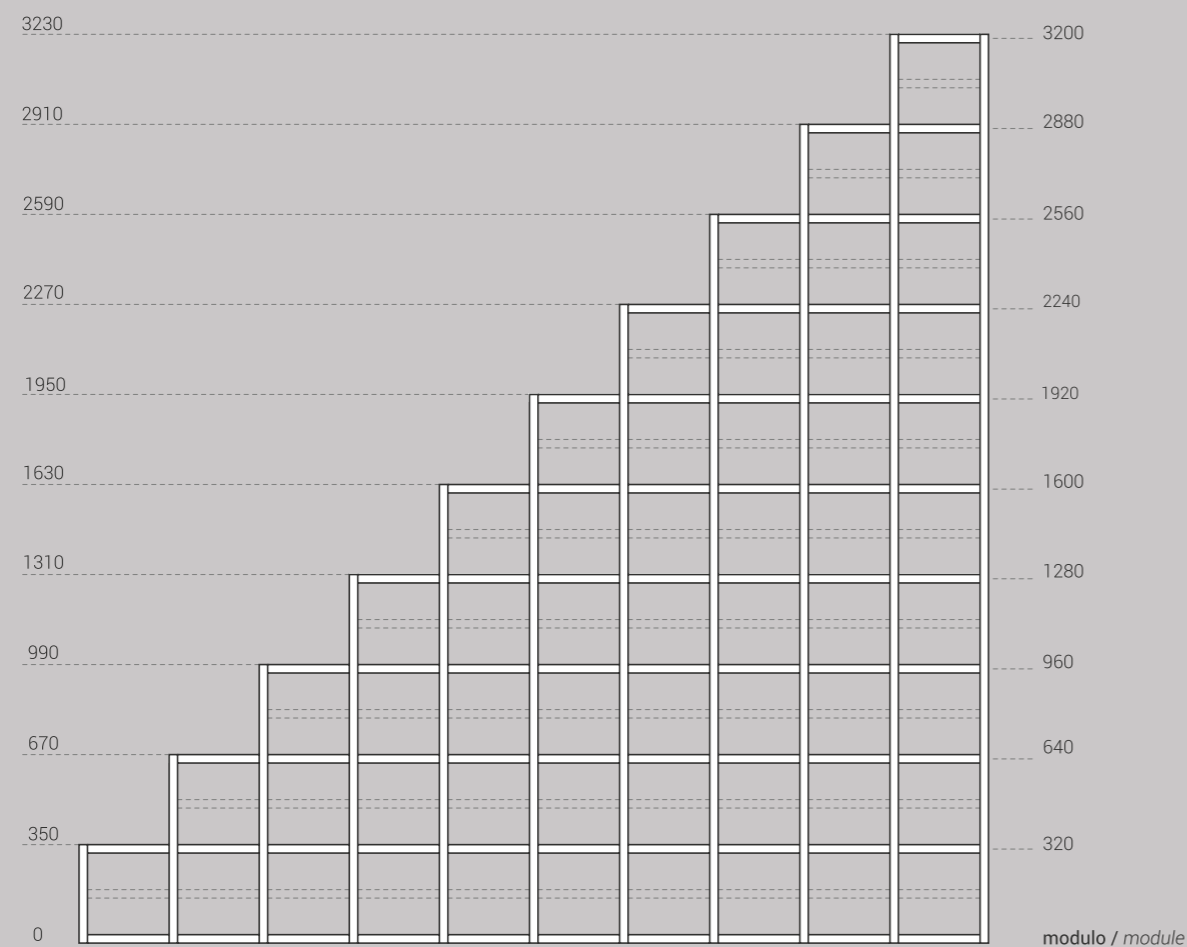

→ PROFONDITÀ / DEPTH

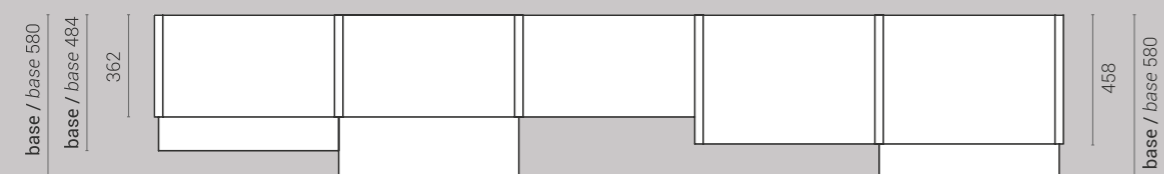

→ SPALLE A TERRA / FREE-STANDING STRUCTURAL SIDE PANELS

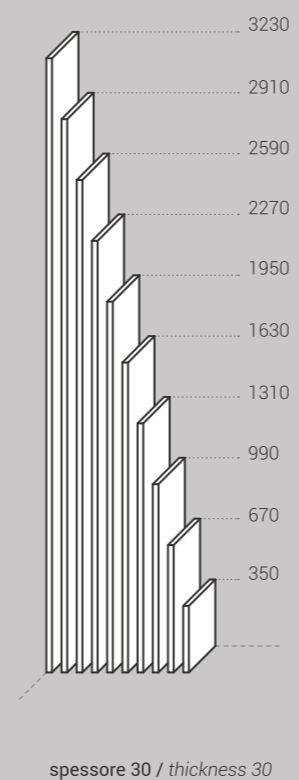

→ SPALLE PER BASI / STRUCTURAL SIDE PANELS FOR BASES

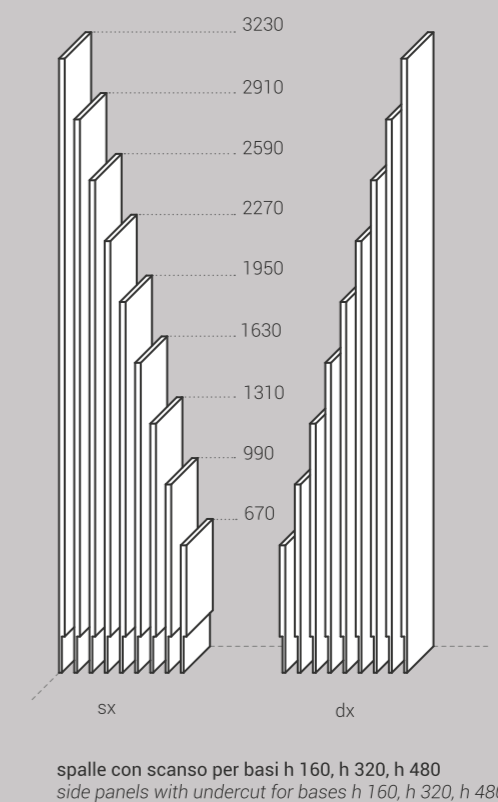

157

→ SPALLE SOVRAPPOSTE A BASI / STRUCTURAL SIDE PANELS SUPERIMPOSED ON BASES

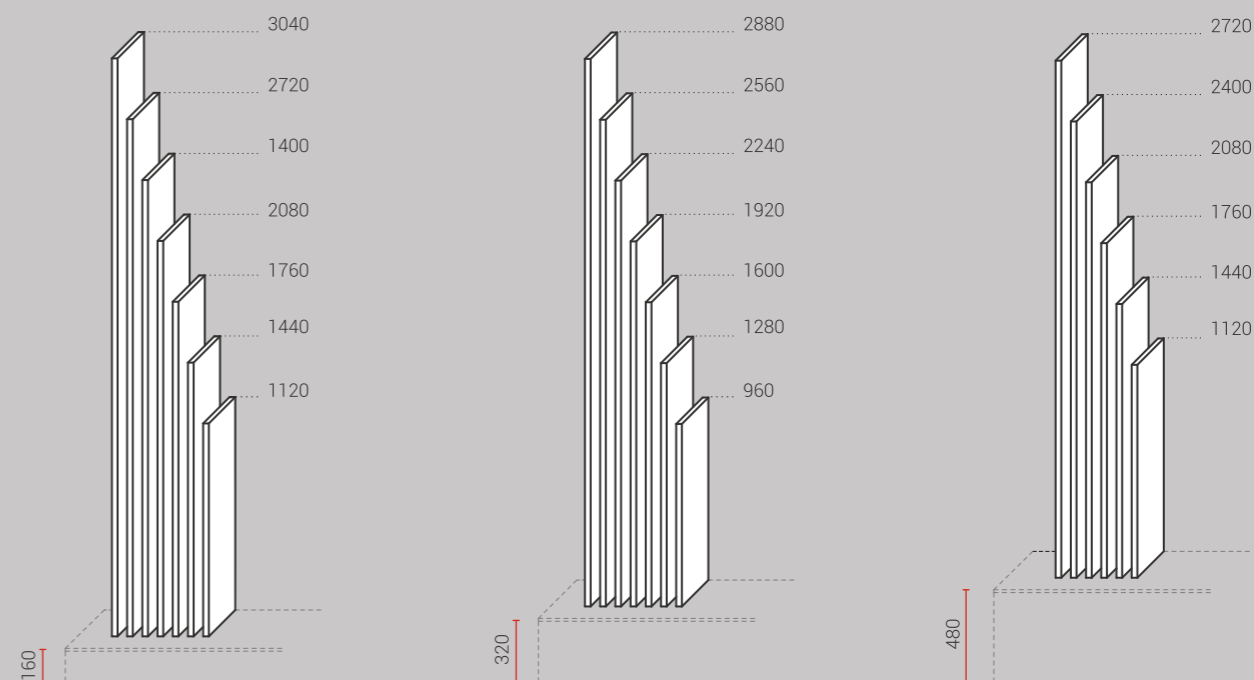

SPEED

→ SPALLE PENSILI / WALL UNIT STRUCTURAL SIDE PANELS

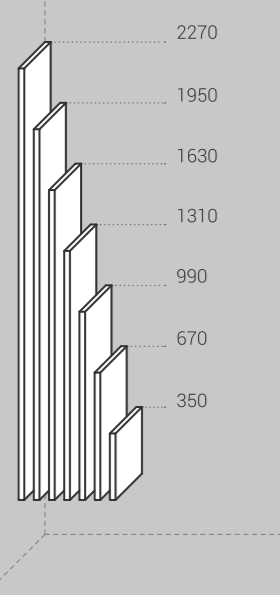

→ SPALLE PENSILI PER BASI SOPESE / WALL UNIT STRUCTURAL SIDE PANELS FOR SUSPENDED BASES

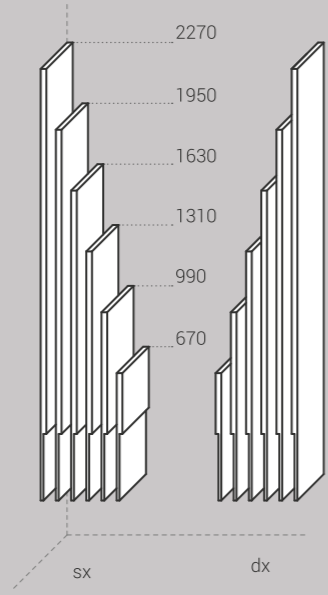

spalle con scanco per basi sospese h. 320, h. 480
side panels with undercut for suspended bases h. 320, h. 480

→ SPALLE PENSILI PER BASI SOPESE / WALL UNIT STRUCTURAL SIDE PANELS FOR SUSPENDED BASES

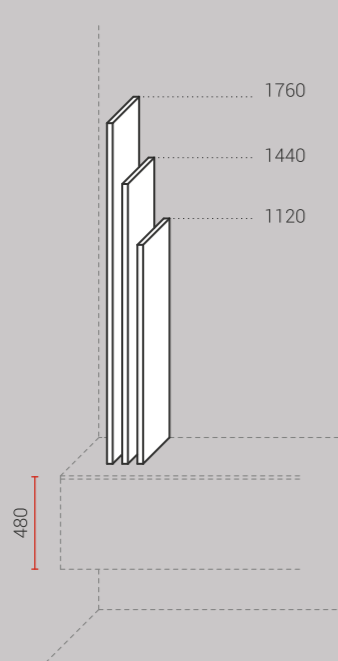
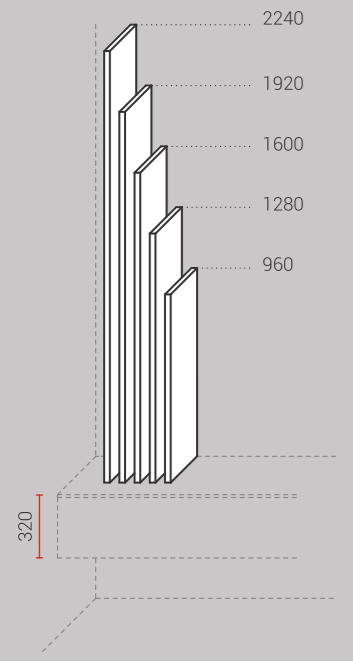

→ DIVISORI TRA RIPIANI / PARTITION BETWEEN SHELVES

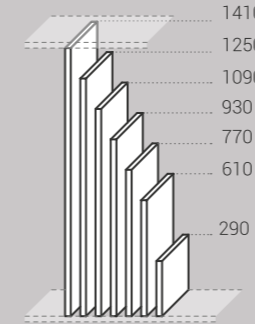

→ TOP

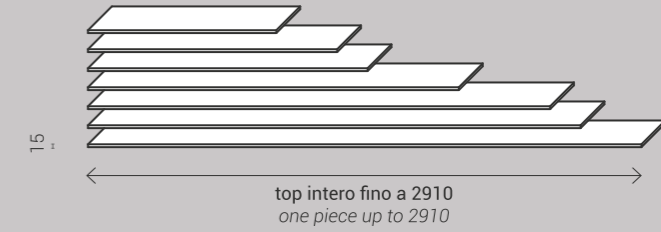

→ RIPIANI PASSANTI / FEEDTHROUGH SHELVES

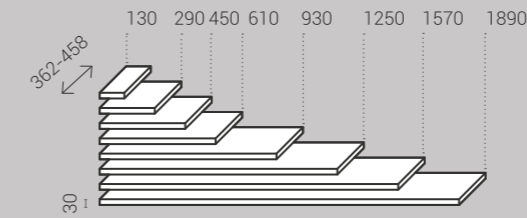

→ RIPIANI SU SCHIENA / SHELVES WITH BACK PANEL

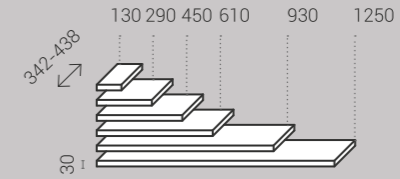

→ RIPIANI SU O SENZA SCHIENA / SHELVES WITH OR WITHOUT BACK PANEL

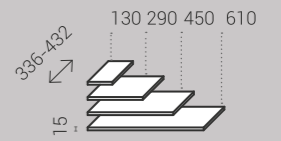

→ RIPIANI IN VETRO / GLASS SHELVES

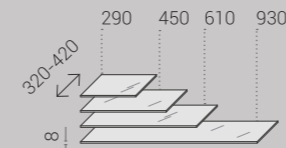

→ SCHIENE / BACK PANELS

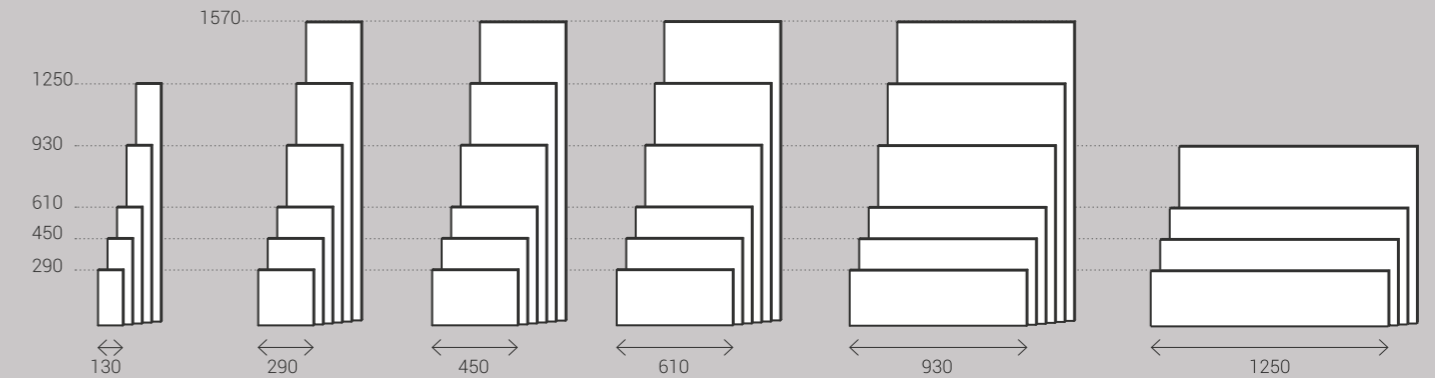

SPEED

MEDIACENTER

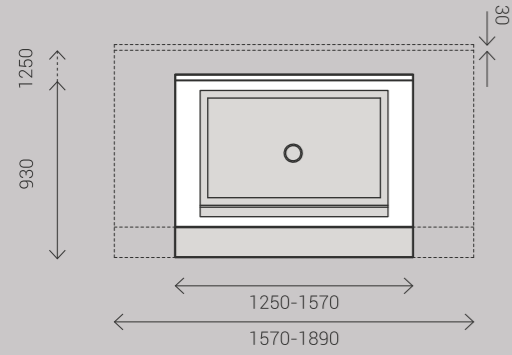

divisione a terra / free-standing partition

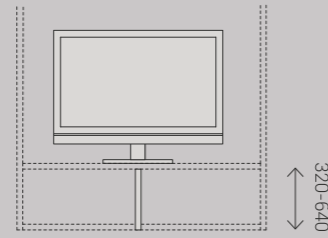

CASSETTI PER VANO DRAWERS FOR COMPARTMENT

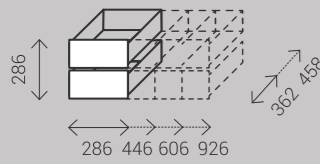

CESTONI PER VANO / DEEP DRAWERS FOR COMPARTMENT

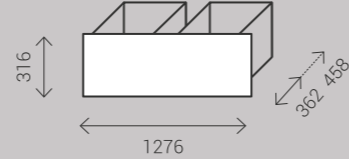
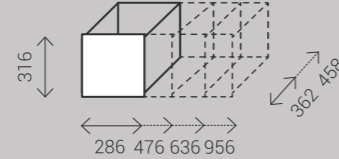
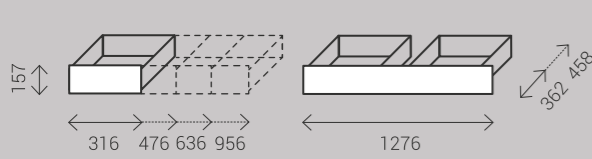
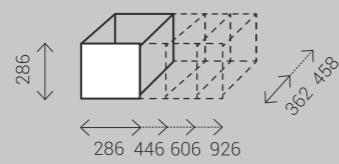

ANTE BATTENTI HINGED DOORS

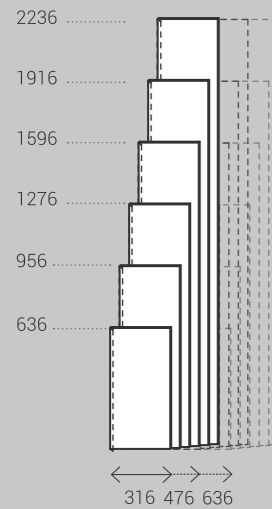

ANTE A RIBALTA FLAP DOORS

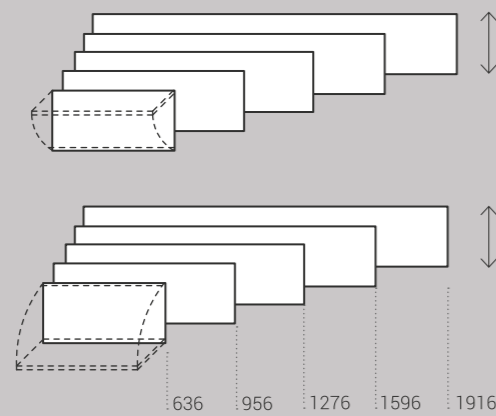

ANTE SCORREVOLI SLIDING DOORS

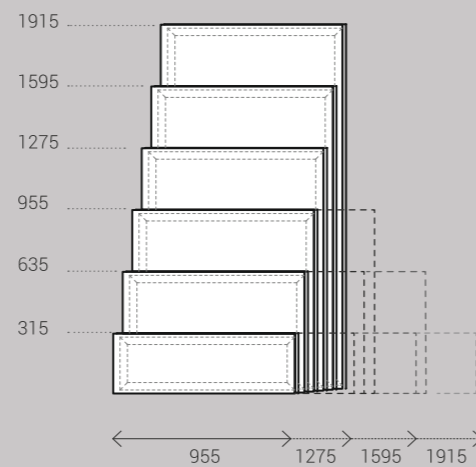

COLONNA PER ANGOLO OPEN CORNER COLUMN

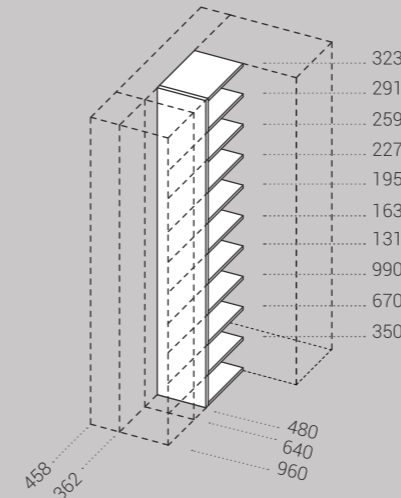

SCALA / LADDER

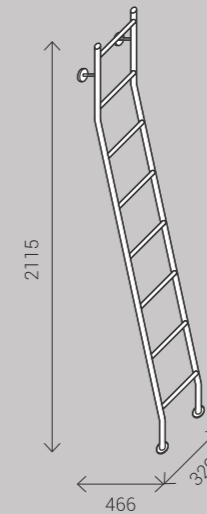

ELEMENTI A GIORNO OPEN ELEMENTS

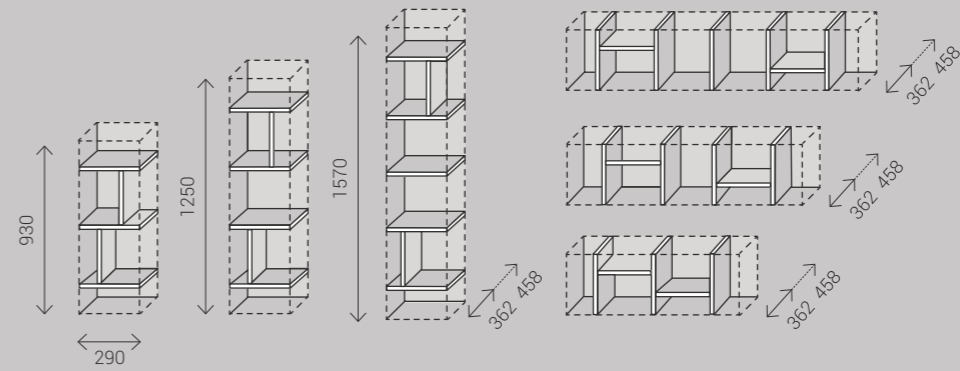

ELEMENTI IN METALLO METAL ELEMENTS

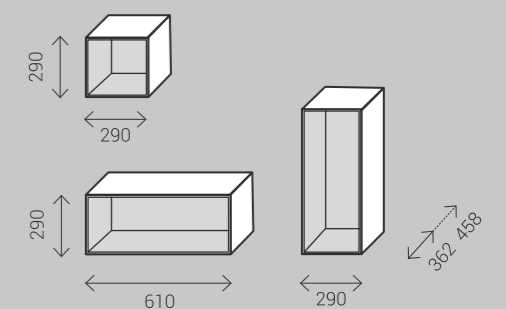

CONTENITORI SPORGENTI JUTTING STORAGE UNITS

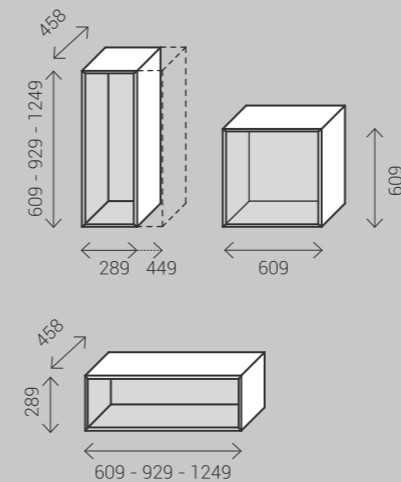

RIPIANI SHELVES

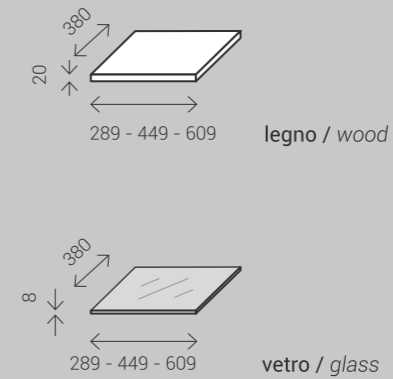

FRONTALI FRONT PANELS

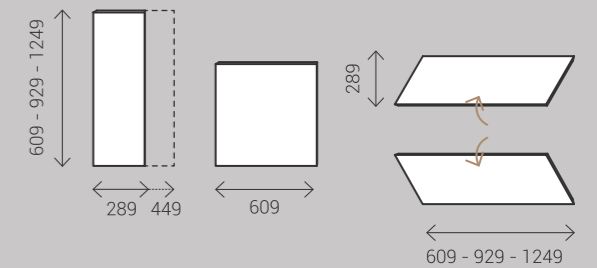

/ FINITURE

finishes / Ausführungen /
finitions / acabados / отделка

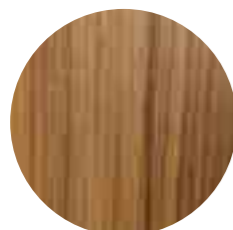

noce canaletto
black american walnut

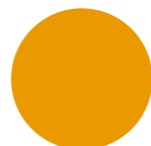

giallo cromo
chrome yellow



blu piombo
gun metal blue



verde pompelmo
grapefruit green



rovere moro
mahogany oak



sabbia scuro
dark sand

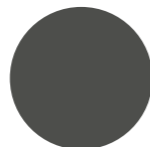

grigio pietra
stone grey



stopsol fumé
smoke-grey stopsol



nero
black

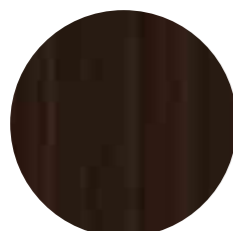

rovere termotrattato
heat-treated oak



grigio medio
medium grey

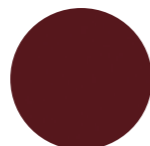

rosso rubino
ruby red



specchio fumo
smoke mirror



magnolia
magnolia



rovere nodi
oak knots

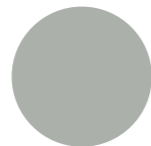

grigio chiaro
light grey



grigio polvere
powder grey



specchio bronzo
bronze mirror



bianco
white

ESSENZE
wood

VETRI
glasses



nero 9017
black



light grey
Y18231



dark grey
Y18232

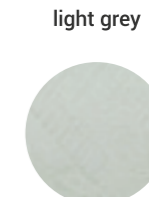

light grey

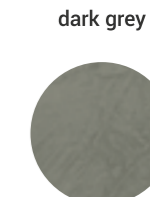

dark grey

EFFETTO RESINA
resin effect



grigio aston 7039
aston grey



corda
rope



canapa
hemp



tortora
dove grey



lilla 228
lilac



blu piombo 255
gun metal blue



grigio perla 238
pearl grey



grigio seta 7044
silk grey



grigio garda 246
garda grey



argento 9006
silver



grigio chiaro 7035
light grey



grigio polvere 252
powder grey



ghiaccio 9002
ice



verde finlandia 199
finland green



verde petrolio 5021
petrol green



verde pallido 190
pale green

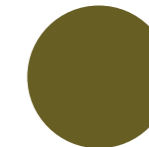

verde muschio 198
moss green



verde pompelmo 192
grapefruit green



rosso bordeaux 3005
bordeaux red



rosso 3003
red



rosso acceso 3001
fiery red



biscotto 2010
biscuit



bruciato 173
burnt



giallo cromo 140
chrome yellow



bianco 9003
white



panna 9010
light cream



fior di loto 1013
lotus flower



crema 9001
cream



senape 1024
mustard



giallo zinco 135
zinc yellow

LACCATI OPACHI E LUCIDI
matt and glossy lacquers

THANK YOU

CONCEPT E ART DIRECTION

imagodesign
arch. Massimo Rosa

GRAPHIC DESIGN

imagodesign - Antonella di Nuzzo

TESTI

imagodesign - Roberta Osso

DIGITAL IMAGES

imagodesign - Marco Brunato e Stefano Adriani

STYLING

imagodesign - Antonella di Nuzzo e Willy Dalto

FOTOLITO E STAMPA

Grafiche Antiga
dicembre 2014

segui Dall'Agnese su / follow us on:

